



IX100/202

Retail Printing Scales

The stylish IX series printing scales offer an outstanding range of features at the lowest price available.

- Most economical scale in its class.
- LCD display shows product description and enables easy programming.
- FREE PC-to-scale software included.
- Choice of models to suit all counters.
- Flexible pre-pack, label & receipt printing from one scale.
- Network up to 9 scales.
- Easy to access, fast loading printer with take-up spool (below).



Designed to suit small independents and convenience stores, the IX series meets the essential needs of the local retailer at the most economical price. With free PC-to-scale software and a compact footprint to suit a variety of counter sizes, it's never been easier to maintain prices, labels and COOL standards.

Features

- **Easy to read, backlit LCD display**
- **Details of up to 1000 products and prices can be stored and recalled**
- **Easy access thermal printer**
- **Wipe clean, membrane keyboard**
- **Envelope pocket for custom keyboard overlay**
- **MX020 - FREE, easy-to-use PC software to manage your scale.**
- **Network up to 9 IX scales**

Dimensions

IX100

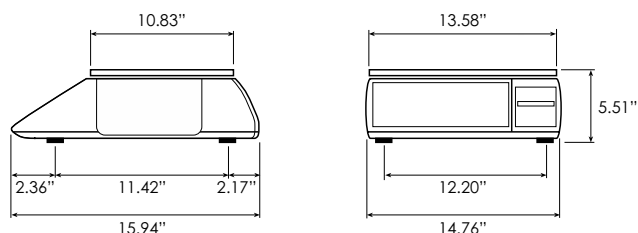

IX202

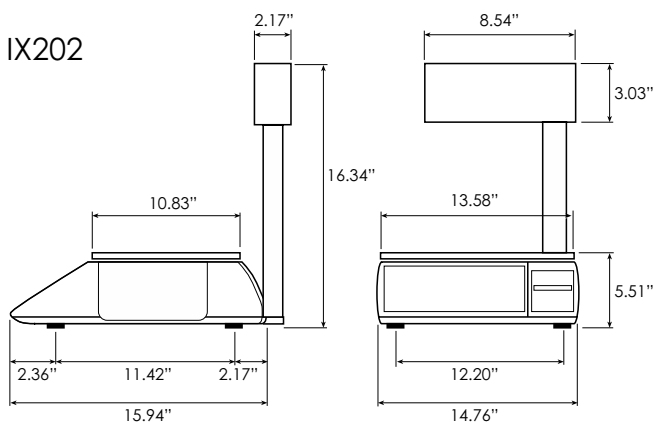

Specifications

- **Design**
IX100 – One-piece modular design.
IX202 – Customer tower display with extended keyboard.
- **Weighing Capacities Available**
15 kg x 5 g.
30 lb x 0.01 lb.
- **Display**
Backlit LCD displays
- **Printer**
Easy-access, thermal label and receipt printer with take-up spool for backing paper:
2.2 in/second print speed.
3.94 in/100 mm diameter roll.
2.2 in/56 mm print width.
- **Keyboard**
Wipe clean keyboard with audible beep.
Fast number entry via cluster key arrangement.
Envelope pocket for keyboard overlay.
IX100 – 57 key keyboard. 36 direct PLUs.
IX202 – 79 key keyboard. 54 direct PLUs.
- **Data Memory**
Details of 1000 products/prices can be stored and recalled.
- **Operators**
Up to eight operators can serve customers from any of the scales on the network.
- **Barcodes**
EAN 8/EAN 13/UPC 12/UPC 13
- **Interfaces**
RS485 scale interface as standard. Nine scales may be linked in a network.
RS232 link to PC or barcode scanner.
Cash drawer interface.
- **Management Reports**
PLU, group and operator totals.



**Avery Weigh-Tronix
(Retail North America)**
1758 Genesis Drive, Suite A
LaPorte, IN 46350

PH Toll-Free: 800-237-1886
PH: 219-325-9587
FAX Toll-Free: 800-237-2063
FAX: 219-325-9594

E-mail: sales@AveryBerkelUSA.com
Internet: www.AveryBerkelUSA.com

